

1 2 3 4 5 6

A

B

C

D

A

B

C

D

5/8-11 THREAD x 1-1/8 DEEP
C'BORE DIA .642 x .300 DEEP

PRECISION GROUND
FOR DUAL CONTACT FIT

Ø 2.50

Ø 1.75

Ø 1.48

Ø .750

LOCK SCREW
3/8-24 x 1.0 SHCS

.645

2.70

0

.04

.75

1.50

2.135

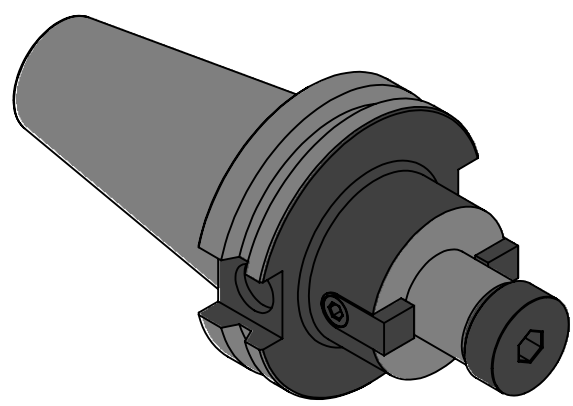

NOTES:
WORKS ON ALL CAT40 MACHINES WITH DUAL CONTACT SPINDLES
COMPATIBLE WITH BIG-PLUS® SPINDLES
HOLDER USES LOCK SCREW 3/8-24 x 1.0 SHCS (INCLUDED)
FOR MORE PRODUCT DETAILS PLEASE GO TO MARITOO.COM
AND SEARCH ITEM # LISTED ON THIS PRINT

MARITOO

WWW.MARITOO.COM

ITEM# **CAT40 FMA.750-1.5MD**

Made in USA

1 2 3 4 5 6